



**SENARAI SEMAK
PENYEDIAAN SPESIFIKASI
PERALATAN RANGKAIAN ICT
KEMENTERIAN KESIHATAN MALAYSIA
BAGI TUJUAN PEROLEHAN**

BAHAGIAN PENGURUSAN MAKLUMAT
KEMENTERIAN KESIHATAN MALAYSIA

**SENARAI SEMAK PENYEDIAAN SPESIFIKASI PERALATAN RANGKAIAN ICT
KEMENTERIAN KESIHATAN MALAYSIA BAGI TUJUAN PEROLEHAN**

BIL	PERKARA	TANDAKAN ✓
1	Gambarajah Rangkaian	
	1.1 Gambarajah Rangkaian Logikal	
	a. Gambarajah Rangkaian Logikal Sedia Ada (As-Is)	
	b. Gambarajah Rangkaian Logikal Yang Dirancang (To-Be)	
	1.2 Gambarajah Rangkaian Fizikal	
	a. Gambarajah Rangkaian Fizikal Sedia Ada (As-Is)	
	b. Gambarajah Rangkaian Fizikal Yang Dirancang (To-Be)	
2	Taburan Peralatan Rangkaian ICT Di Fasiliti	
3	Format Spesifikasi Perolehan Peralatan Rangkaian	
4	Anggaran Kos Peralatan Rangkaian	
	4.1 Kajian Pasaran	
	4.2 Taburan Anggaran Kos Peralatan Rangkaian ICT	
5	Justifikasi Perolehan Peralatan Rangkaian	
6	Laporan Heatmap (<i>jika terdapat perolehan Wireless Access Point</i>)	



RUJUKAN

Dokumen ini perlu dibaca bersama dengan dokumen-dokumen berikut:

- a) Garis Panduan Penyediaan Spesifikasi Peralatan Rangkaian ICT
Kementerian Kesihatan Malaysia
- b) Katalog Anggaran Harga JDN

Nota:

Untuk mendapatkan anggaran harga bagi setiap perolehan, PNET mengutamakan kajian pasaran yang dibuat oleh fasilititi dari pihak pembekal. Katalog anggaran harga JDN adalah rujukan umum sahaja dan tidak menggambarkan situasi sebenar peralatan rangkaian di fasilititi.



1.0 GAMBARAJAH RANGKAIAN

1.1 GAMBARAJAH RANGKAIAN LOGIKAL

Rajah rangkaian logikal menerangkan cara maklumat bergerak melalui rangkaian. Oleh itu, rajah rangkaian logikal biasanya menunjukkan subnet (termasuk ID VLAN, topeng, dan alamat), peralatan rangkaian seperti suis, firewall, dan protokol penghalaan.

Logical vs Physical Network Diagrams

Logical Network Diagram

- Shows how data behaves between network devices
- Lines represent data flow, not physical cables

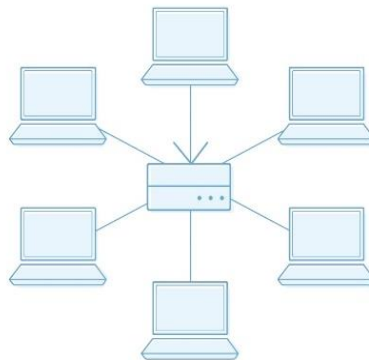

Physical Network Diagram

- Represents your network's physical devices and cables
- Lines represent cable connections rather than data flow



a. Gambarajah Rangkaian Logikal Sedia Ada (AS-IS)

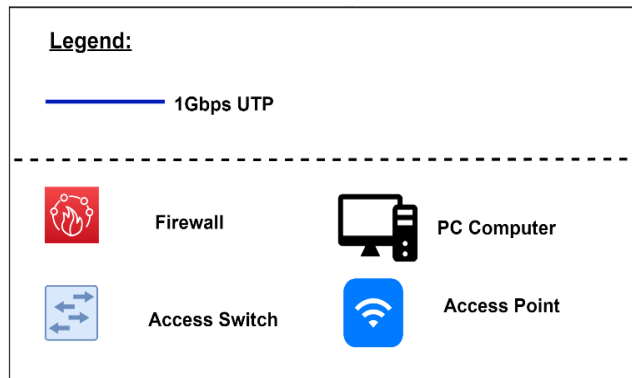
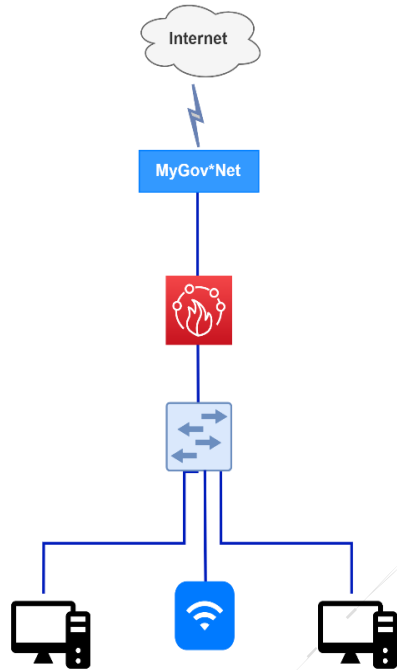

Contoh rajah rangkaian logikal sedia ada (AS-IS)



b. Gambarajah Rangkaian Logikal Yang Dirancang (TO-BE)

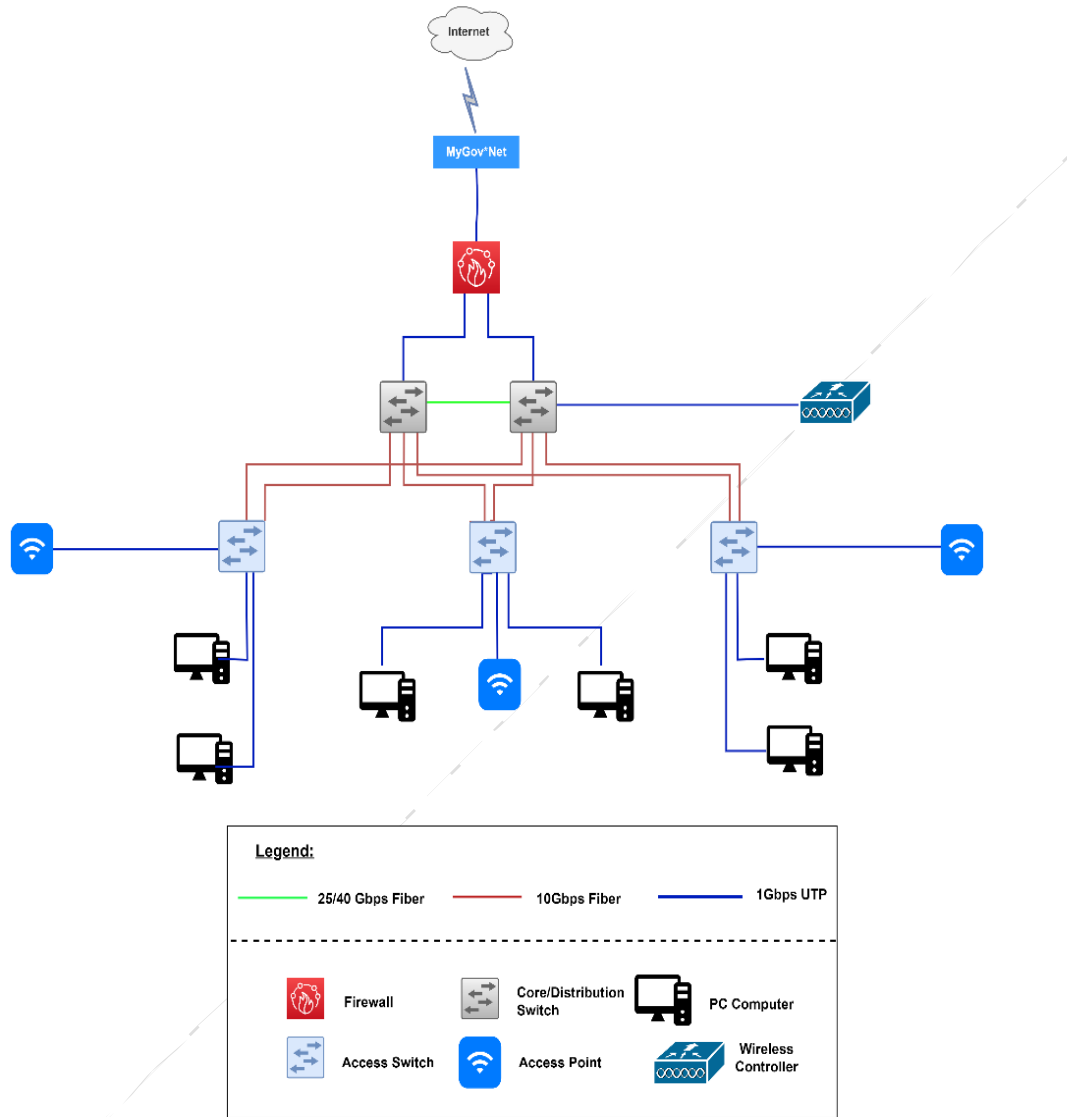

Contoh rajah rangkaian logikal yang dirancang (TO-BE)



1.2 GAMBARAJAH RANGKAIAN FIZIKAL

Rajah rangkaian fizikal biasanya digunakan untuk menggambarkan sambungan antara peralatan rangkaian dan komponen fizikal lain. Ia memaparkan topologi dan kewujudan jaringan fizikal antara peralatan. Banyak digunakan oleh kakitangan IT, rajah rangkaian fizikal mendokumentasikan sambungan fizikal secara visual.

Logical vs Physical Network Diagrams

Logical Network Diagram

- Shows how data behaves between network devices
- Lines represent data flow, not physical cables

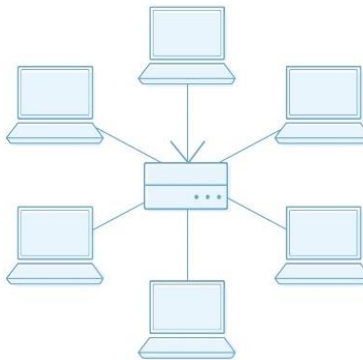

Physical Network Diagram

- Represents your network's physical devices and cables
- Lines represent cable connections rather than data flow



a. Gambarajah Rangkaian Fizikal Sedia Ada (AS-IS)

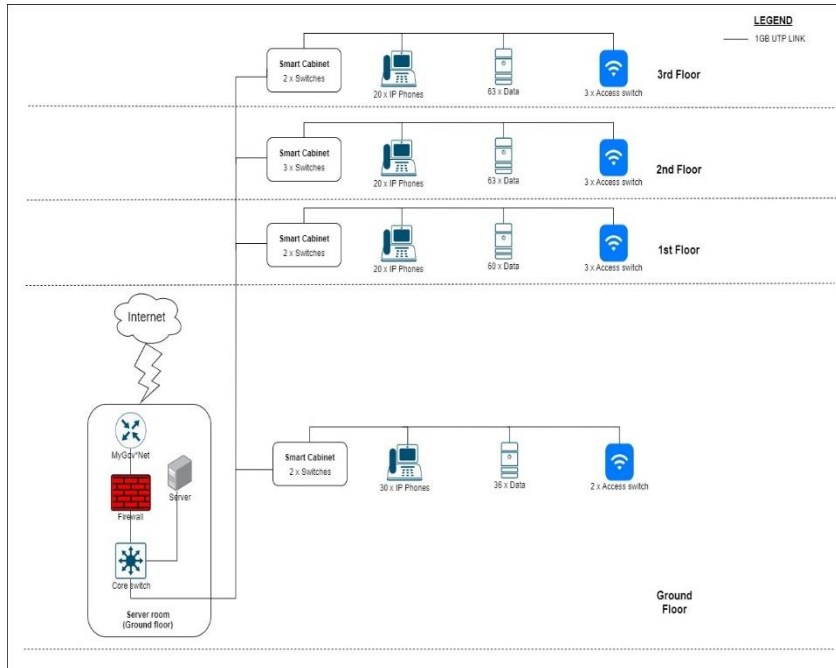

Contoh rajah rangkaian fizikal sedia ada (AS-IS) bagi fasiliti yang mempunyai satu blok bangunan

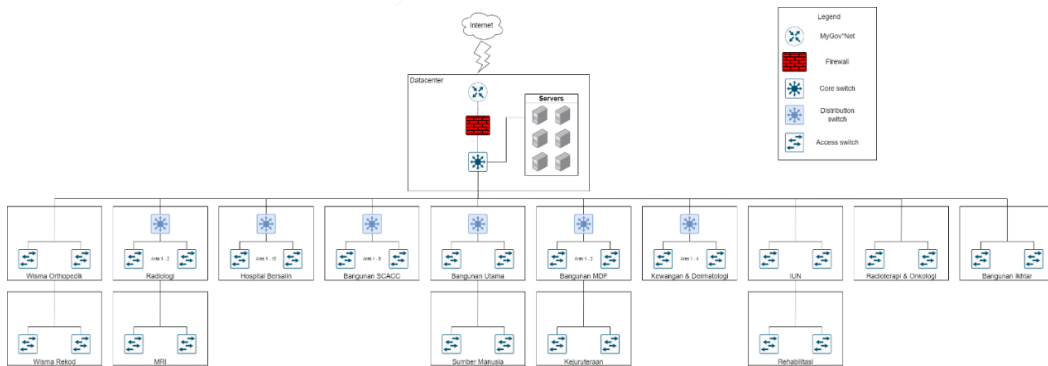

Contoh rajah rangkaian fizikal sedia ada (AS-IS) bagi fasiliti yang mempunyai lebih dari satu blok bangunan



b. Gambarajah Rangkaian Fizikal Yang Dirancang (TO-BE)

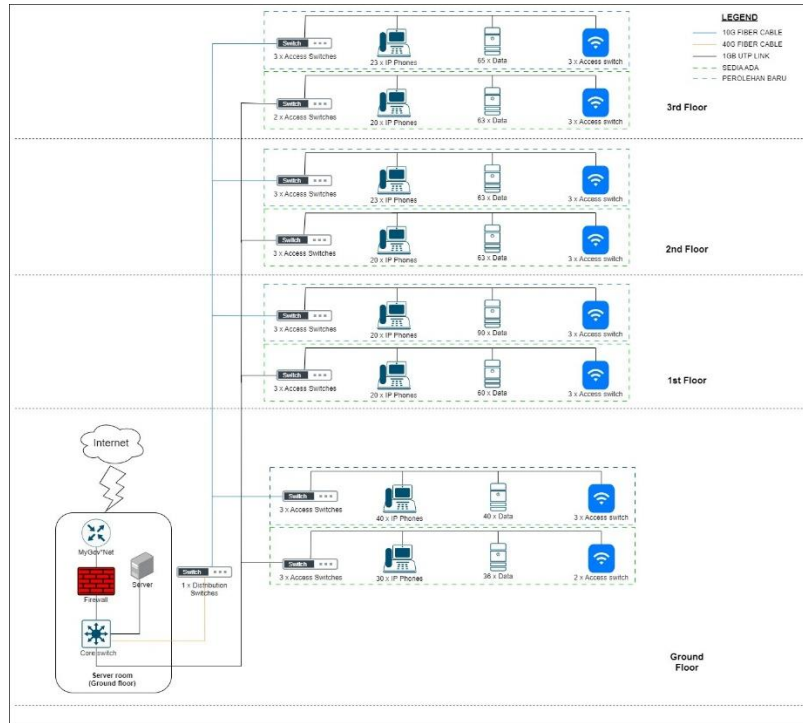

Contoh rajah rangkaian fizikal yang dirancang (TO-BE) bagi fasiliti yang mempunyai satu blok bangunan

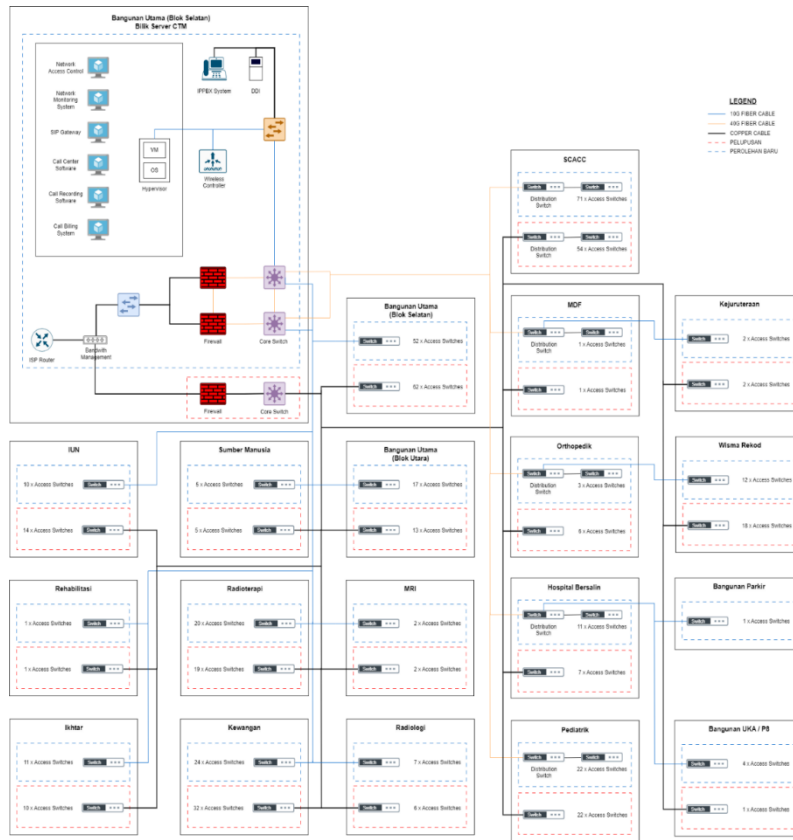

Contoh rajah rangkaian fizikal yang dirancang (TO-BE) bagi fasiliti yang mempunyai lebih dari satu blok bangunan



2.0 TABURAN PERALATAN RANGKAIAN ICT DI FASILITI

Kenalpasti komponen rangkaian utama yang diperlukan di fasiliti seperti pelayan (server), susi (switch), titik akses (access point), penghala (router), dinding api (firewall) dan lain-lain peralatan rangkaian. Contoh taburan peralatan rangkaian adalah seperti di bawah:

LOKASI	SEDIA ADA					PEROLEHAN						AKAN LUPUS		
						PEROLEHAN BARU		PENGANTIAN						
	Firewall	Switch	Wireless AP	UTP Lan	UTP Patch Panel	Wireless Controller	Fiber indoor	Firewall	Switch	Wireless AP	UTP Lan	Firewall	Switch	Wireless AP
Bilik Server	1	10	5	140	4	1	1	2	20	10	0	1	10	5
Bangunan A	0	2	2	50	2	0	0	0	5	5	0	0	2	2
Bangunan B	0	1	1	10	1	0	0	0	2	2	0	0	1	1
Parkir	0	0	0	2	0	0	0	0	0	0	2	0	0	0
Sumber Manusia	0	1	2	5	1	0	0	0	1	5	10	0	1	2
JUMLAH	1	14	10	207	8	1	1	2	28	22	12	1	14	9



3.0 FORMAT SPESIFIKASI PEROLEHAN PERALATAN RANGKAIAN

CONTOH

FORMAT SPESIFIKASI - CORE SWITCH

KATEGORI SPESIFIKASI CORE SWITCH	SPESIFIKASI TEKNIKAL CORE SWITCH
Capacity and Performance	<ul style="list-style-type: none">- Switching capacity: Min 4.8 Tb/s- Forwarding rates: Min 2976 Mpps- Latency: <450 ns
Scalability and Port Density	<ul style="list-style-type: none">- Modular switch/stackable to standby for current needs and future growth- 48 ports, support 1G/10G SFP+ ports and 25G/40G/200G SFP28/QSFP28 ports
Redundancy and High Availability	<ul style="list-style-type: none">- Redundant and hot-swappable power supplies- Supported for High Availability (HA) such as Virtual Router Redundancy Protocol (VRRP) or Hot Standby Router Protocol (HSRP)- In-Service Software Upgrade (ISSU)
Network Management and Monitoring	<ul style="list-style-type: none">- Support for Simple Network Management Protocol (SNMP), Command Line Interface (CLI) and web interface- Some of advanced monitoring capabilities such as traffic analysis, performance statistics and network health monitoring
Safety Features	<ul style="list-style-type: none">- Equipped with enhanced safety features such as Access Control List (ACL), Virtual Local Area Network (VLAN), port security and Denial of Service (DoS) protection- Authentication standards such as 802.1X, address filtering, Media Access Control (MAC) and Role-Based Access Control (RBAC)
Quality of Service (QoS)	<ul style="list-style-type: none">- Comes with traffic classification specifications such as queuing mechanism and bandwidth control
Routing Layer 3 Ability	<ul style="list-style-type: none">- Routing Layer 3 supported such as Virtual Local Area Network (VLAN), Spanning Tree Protocol (STP), Routing Information Protocol (RIP), Open Shortest Path First (OSPF)
Stacking and Virtualization	<ul style="list-style-type: none">- Support stacking technologies or virtualization for network management and high scalability
Energy Efficient	<ul style="list-style-type: none">- Energy-Efficient Ethernet (IEEE) 802.3az
Supplier Support and Future Roadmap	<ul style="list-style-type: none">- Firmware upgrade, bug fixing and relevance with emerging technologies



DIISI OLEH PEMOHON

FORMAT SPESIFIKASI - CORE SWITCH

KATEGORI SPESIFIKASI CORE SWITCH	SPESIFIKASI TEKNIKAL CORE SWITCH
Capacity and Performance	
Scalability and Port Density	
Redundancy and High Availability	
Network Management and Monitoring	
Safety Features	
Quality of Service (QoS)	
Routing Layer 3 Ability	
Stacking and Virtualization	
Energy Efficient	
Supplier Support and Future Roadmap	



4.0 ANGGARAN KOS PERALATAN RANGKAIAN

4.1 Kajian Pasaran

Fasiliti perlu mengemukakan minimum 3 kajian pasaran sebenar yang diperolehi dari pihak pembekal (berserta *letter head*).

NOTA : Perolehan sewa guna untuk tempoh 5 tahun (tidak dibenarkan meletakkan kenyataan "Limited lifetime warranty" untuk spesifikasi peralatan)



4.2 Taburan Anggaran Kos Peralatan Rangkaian ICT Berdasarkan Format JTISA

BIL.	PERKARA	KUANTITI	HARGA SEUNIT (RM)	JUMLAH (RM)	CATATAN
	Contoh: Wireless Access Point - 802.11ax 2x2 Triple Radio Indoor, 5dBi antenna gain @ 5Ghz	8	5,127.35	41,018.80	Peralatan akan ditempatkan di bangunan HKL bagi kemudahan capaian Wi-Fi kakitangan.
1.					
2.					
3.					
4.					
5.					



5.0 JUSTIFIKASI PEROLEHAN PERALATAN RANGKAIAN

BIL.	PERALATAN RANGKAIAN	TUJUAN PEROLEHAN	IMPLIKASI JIKA TIDAK DILAKSANAKAN
	Contoh: Core Switch	Teknologi baharu – memerlukan port fiber sebagai penyambungan <i>backbone</i>	Penyambungan backbone tidak dapat dinaik taraf dari kabel UTP ke kabel fiber
1.			
2.			
3.			
4.			
5.			



6.0 LAPORAN HEATMAP (jika terdapat perolehan Wireless Access Point)

Fasiliti perlu menyediakan laporan heatmap bagi mengesahkan keperluan kuantiti yang dicadangkan berdasarkan lokasi yang dipilih.

Laporan heatmap hendaklah disediakan seperti rajah di bawah:



Contoh laporan Heatmap Aras 2